



Wall panels

Instruction for installation and use

Instruction for installation

1. General information:

- 1.1 Wall panels should be stored indoors, on a dry, flat and stable surface, which prevents direct contact with the ground, in a horizontal position, at a temperature no higher than 60°C, and should not be directly exposed to sunlight.
- 1.2 Wall panels should be transported in a horizontal position, at a temperature not exceeding 60°C.
- 1.3 Before installation, season wall panels in the room where they will be installed, for minimum 24h, in order to adjust their temperature with the ambient temperature.
- 1.4 Unpack the product and compare the colours before installation. Minimum shade differences are admissible.
- 1.5 We recommend finishing the panels with dedicated trims. While installing 105 panels, both the tongue and the groove should be cut off. In the case of 250Q, cut off only the tongue. Detailed information can be found in the finishing trims installation manual.
- 1.6 Do not apply wall panels in places exposed to high temperatures (above 60°C), e.g. in saunas, on chimneys, by cookers; in rooms exposed to temperature fluctuation exceeding 10°C; in places highly exposed to sunlight.
- 1.7 The product may be installed in wet rooms (kitchens, bathrooms) provided it is sealed with silicone.
- 1.8 Do not modify the product by machining its surface or covering it with a layer of another material.
- 1.9 If any visible flaws emerge or irregularities are detected, report them immediately to the seller before installation.
- 1.10 Observe all the rules indicated in the instruction for installation and use. Failure to observe the instructions shall invalidate the product warranty.
- 1.11 The product is intended for indoor use only.
- 1.14 The product is 100% recyclable.

2. Installation

- 2.1 Wall panels should be installed on a frame or using an adhesive.
- 2.2 Wall panels should be mounted in vertical position.
- 2.3 The installation should be carried out by persons with basic technical expertise and knowledge of safety rules.
- 2.4 Wall panels should be mounted from the left to the right, observing the numbers located at the back of each panel.
- 2.5 After applying the first panel, check its vertical position and mount it, then attach the next panel.

Frame construction

- 2.6 The frame should be made of wooden battens mounted directly on the wall.
- 2.7 All the battens should be adjusted with a level, so they form an even surface: use washers or wedges to align the battens, if necessary.
- 2.8 The battens should be perpendicular to the direction of installing the panels – if the panels are installed vertically, the battens must be mounted horizontally.
- 2.9 Distance between battens – 40 cm.
- 2.10 Requirements for the battens: - made of high-quality timber, free from knots, mounted on the wall in a firm and solid way using screws or other mounting elements

appropriate for a given floor type; the battens should be stored for at least 24h in the room where they will be installed (in order to adjust the temperature and moisture content).

Installation on a frame

- 2.11 Mount the panels to the battens using the tongue, on the long side.
- 2.12 The staple should adhere in such a way not to damage the subsequent panel.

Installation using an adhesive

- 2.13 Appropriately prepare the floor – it must be smooth and may not crumble.
- 2.14 We recommend using a highly elastic adhesive based on hybrid polymers, suitable for interior use and for gluing any construction materials, also wet materials such as concrete, brick, gypsum boards, natural stone, wood and wood-based materials, metals, glass and ceramic materials, the majority of plastics, e.g. PVC, styrofoam, polyacrylates and polycarbonates, e.g. Vilo adhesive.
- 2.15 Use the adhesive in accordance with its manual, in a well ventilated room.
- 2.16 Apply the adhesive on the panels making the “S” shape.
- 2.17 The first panel mounted on the wall must be covered with adhesive on the entire surface, each subsequent panel – only by the edge with the tongue.

Cutting the panels

- 2.18 Machining of wall panels should be performed using conventional woodworking tools for cutting or drilling, such as hand saw, fret saw or saw bench. Use fine toothed saws; mechanic tools for machining should be used with the same or higher speeds as for woodworking.
- 2.19 While finishing the floor panels with B1-B5 finishing profiles, remember to cut off the tongue.

3. Information for use

- 3.1 The panels should not be additionally loaded and should not have any bearing functions.
- 3.2 Do not screw hangers, shelves or other elements directly to the panels.
- 3.3 It is permitted to mount elements on the floor located under the panel, using appropriate screws or pins suitable for a given floor type. To do this, drill a proper hole in the panel.

4. Cleaning and maintenance

- 4.1 Cleaning and maintenance
- 4.2 Clean wall panels using water, a light detergent and a cloth; do not leave detergents on the surface, thoroughly rinse them after cleaning.
- 4.3 Do not clean wall panels with sharp or rough cloths, sponges or brushes.
- 4.4 Intensive scrubbing, using strong cleaning agents or leaving the detergents without rinsing may damage the panel surface or decolour the material.
- 4.5 Do not use solvents, acids, bases or their derivatives for cleaning.

1

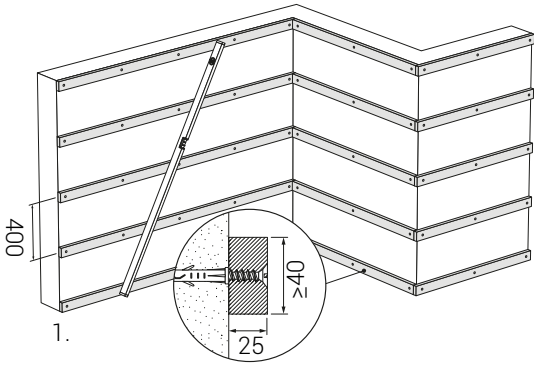

2

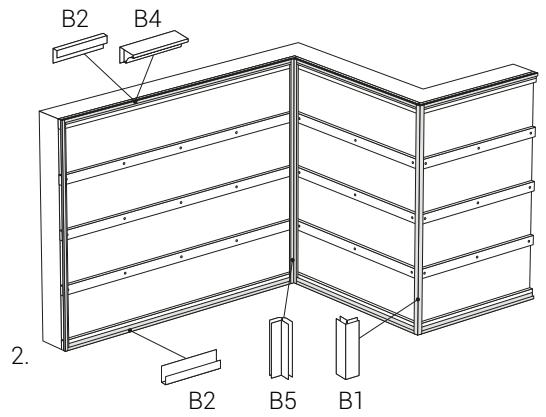

3

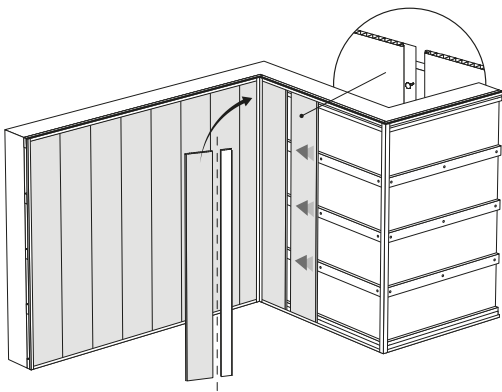

4

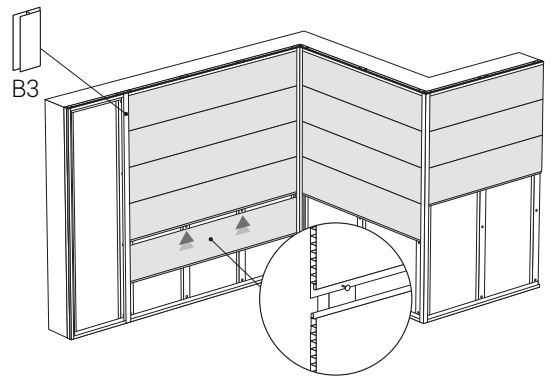

5

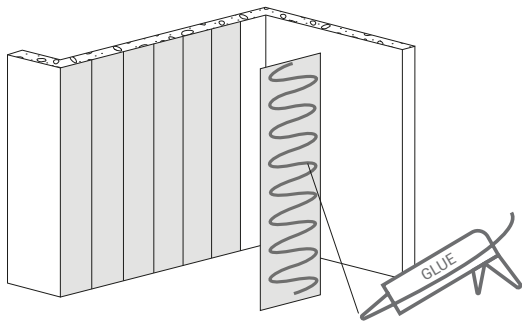

6

